

Enzymology: recalls

Michaelis-Menten kinetics

The model is an equation describing the rate of enzymatic reactions when the reaction is catalyzed by one enzyme acting on an unique substrate to give a product (the enzyme is an activator of the reaction).



$$\frac{dP}{dt} = v_{\max} \frac{[S]}{K_m + [S]}$$

Where P is the product, S the substrate, v_{\max} is the maximal synthesis rate of P and K_m is the required concentration of S for half-maximal synthesis rate ($v_{\max}/2$)

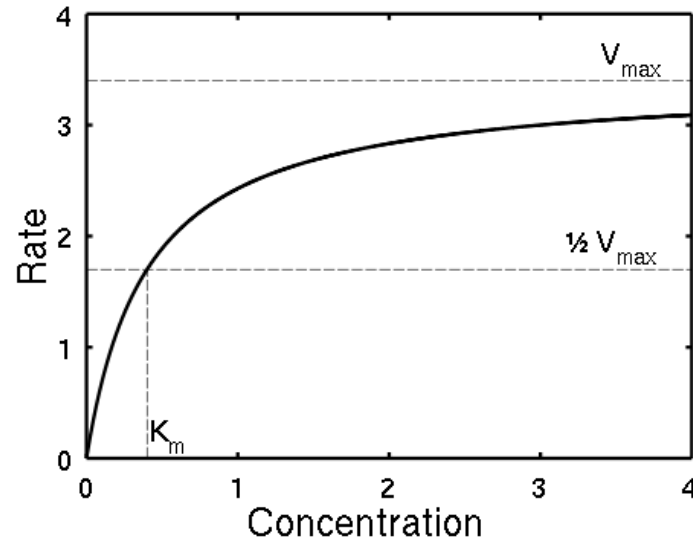

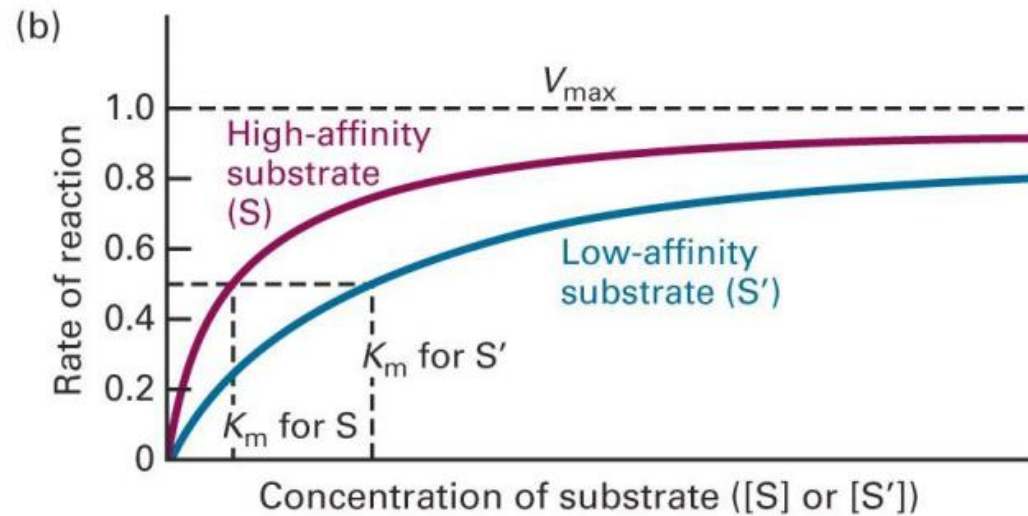
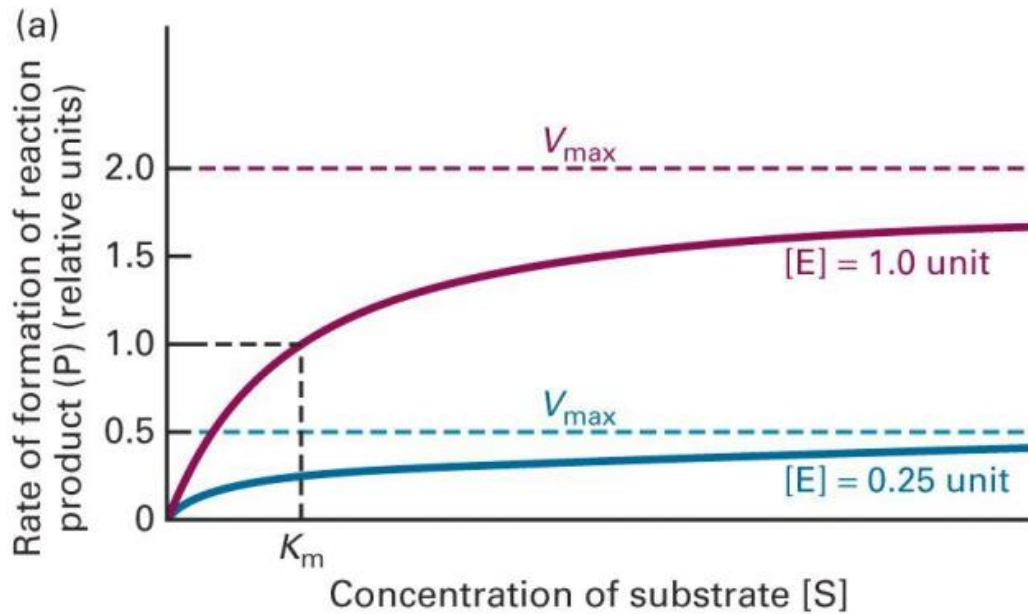

$$v = \frac{v_{max} [S]_0}{[S]_0 + K_M}$$

- v_{max} : Maximal reaction velocity.
- K_M : Affinity enzyme-substrate (substrate conc. at half-maximal rate).

Activators - inhibitors

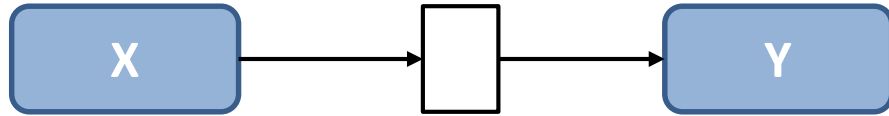

$$\frac{d[y]}{dt} = v$$

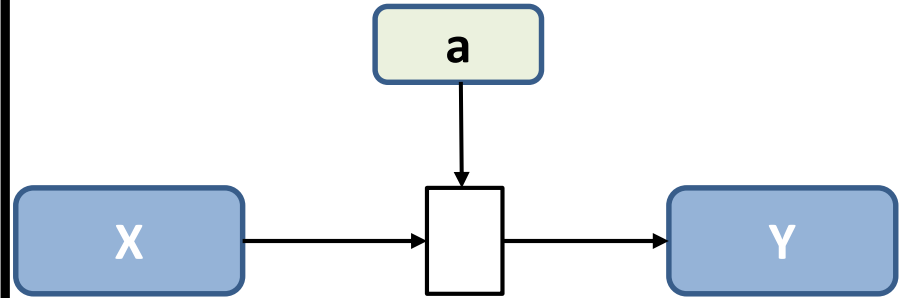

$$\frac{d[y]}{dt} = v \frac{[a]^n}{K_a^n + [a]^n}$$

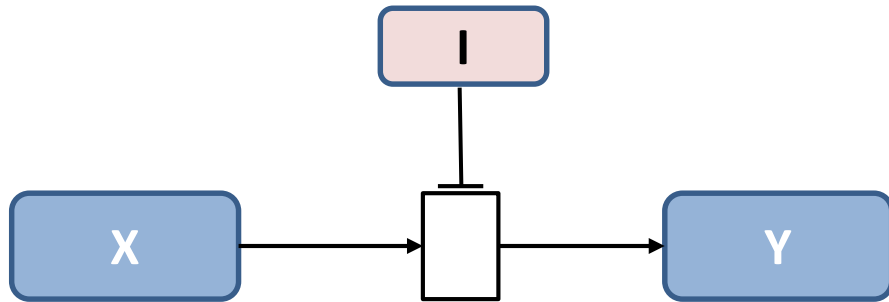

$$\frac{d[y]}{dt} = v \frac{K_I^n}{K_I^n + [I]^n}$$

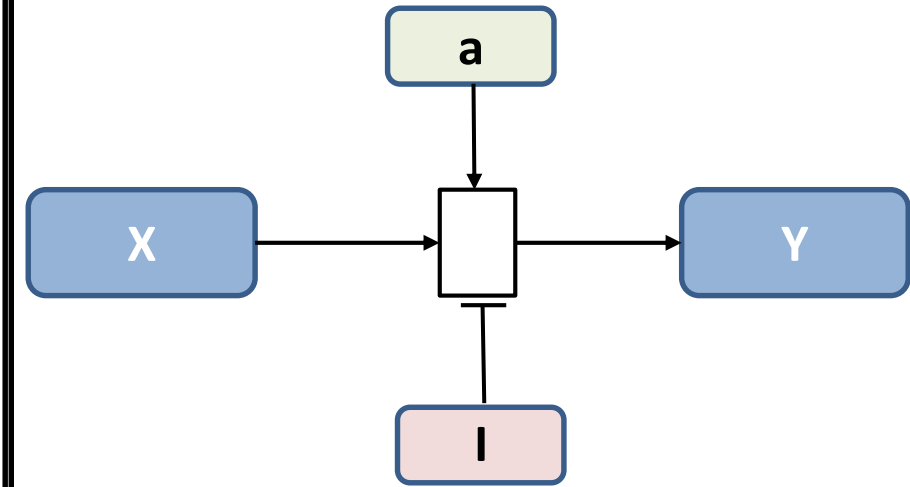

$$\frac{d[y]}{dt} = v \frac{[a]^n}{K_a^n + [a]^n} \frac{K_I^n}{K_I^n + [I]^n}$$

Competitive inhibition

Competitive inhibition (isosteric inhibition): the inhibitor binds to the same sites as the substrate. So there is competition between substrate and inhibitor for the binding site.

In this case, if the substrate concentration is increased, the probability of binding of the substrate relative to the inhibitor is increased.

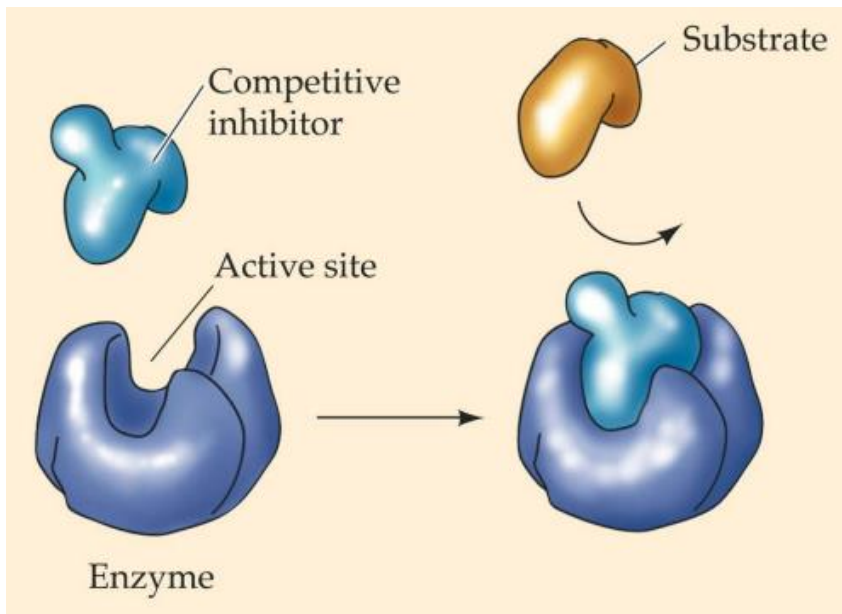

$$\frac{dP}{dt} = \frac{V_{max} [S]}{[S] + K_M \left[1 + \frac{[I]}{K_I} \right]}$$

with K_I dissociation constant

Competitive inhibition

Non Competitive inhibition (allosteric inhibition) : the inhibitor does not bind to the same sites as the substrate but affects the rate of the reaction by binding to another site. Increasing the substrate concentration has no effect on the inhibition.

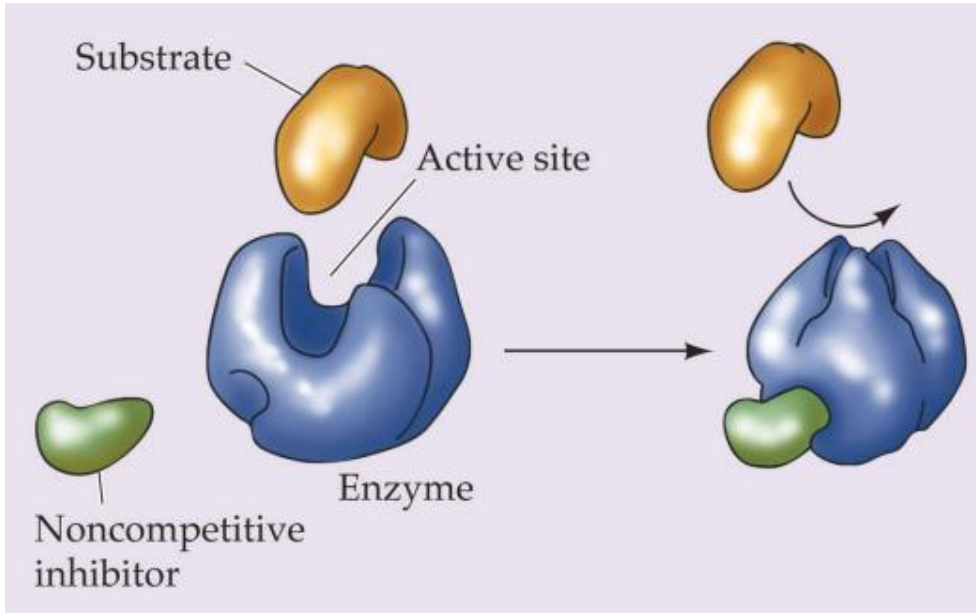

$$\frac{dP}{dt} = \frac{V_{max}}{1 + \frac{[I]}{K_I}} \frac{[S]}{[S] + K_M}$$

$$\frac{dP}{dt} = \frac{V_{max} [S]}{[S] + [K_m]} \left(1 - \frac{[I]}{K_I + [I]} \right)$$

Competitive inhibition

Competitive inhibition

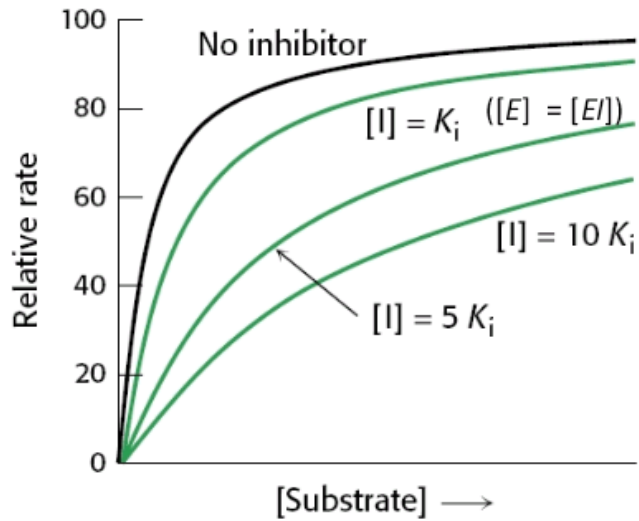

Non competitive inhibition

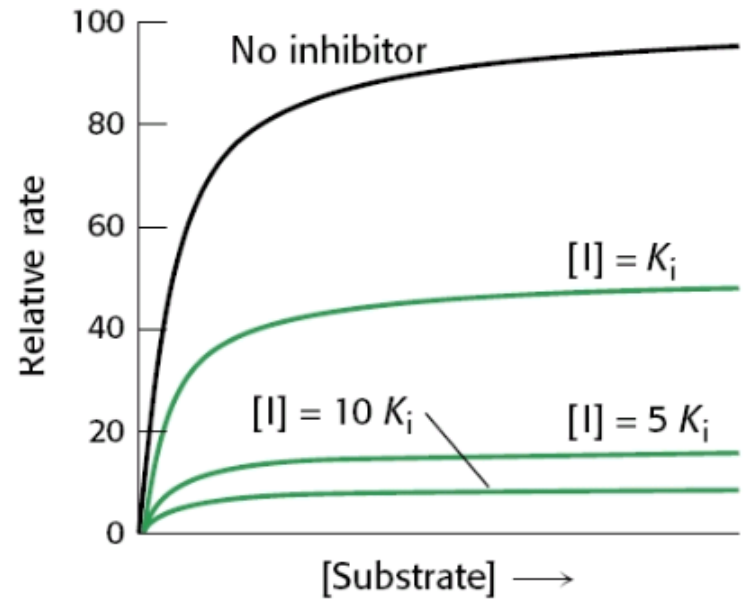

Hill function - Hill kinetics - Cooperativity

Many proteins are known to be oligomeric and/or have more than one binding site for their interaction partners. Binding of the first ligand may alter the binding characteristics of all binding sites. This ability is termed cooperative binding. If ligand binding increases the affinity of subsequent ligand binding, then it is termed positive cooperativity, otherwise it is called negative cooperativity. One of the characteristics of positive cooperativity on a reaction rate is to generate a sigmoid curve.

$$\frac{dP}{dt} = v_{\max} \frac{[X]^n}{K^n + [X]^n}$$

K is the Hill constant = concentration of X at which the reaction proceeds as half its maximum speed.
 n is the Hill coefficient. The greater is n , the steeper is the response

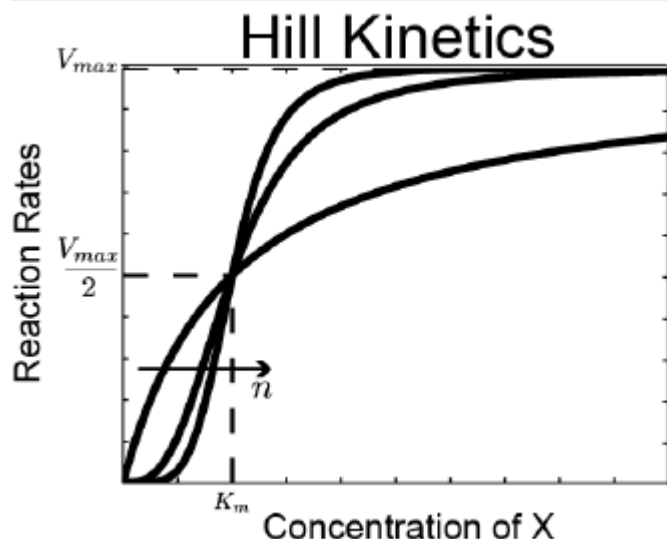

Hill function – transcriptional regulator

Case : rate of production of a protein Y controlled by a single transcription factor X

The strength of the effect of the transcription factor on the transcription rate of its target gene is described by an **input function**. In our case, the number of proteins Y produced per unit time is a function of the concentration of X under its active form X^* . The input function $f(X^*)$ is a monotonic, S-shaped function. A useful function that describes many real gene input functions is the Hill function. For an **activator**, the Hill function is a curve that rises from 0 and approaches a maximal saturated level. It is given by:

$$\frac{d[Y]}{dt} = f(X^*) = \frac{\beta_{\max} [X^*]^n}{K^n + [X^*]^n}$$

With β_{\max} is maximal transcription rate of the promoter-transcription factor complex

X^* is the concentration of the active form of X

K is the activation coefficient, *i.e.*, the required concentration of X^* to reach the half-maximal expression ($\beta_{\max}/2$)

and n is the Hill coefficient that governs the steepness of the curve, the higher n , the more step-like the input function. This coefficient comes from the fact the transcription factors can act as multi-mers which leads to cooperative behavior. Typical values for n are 1–4

Hill function – transcriptional regulator

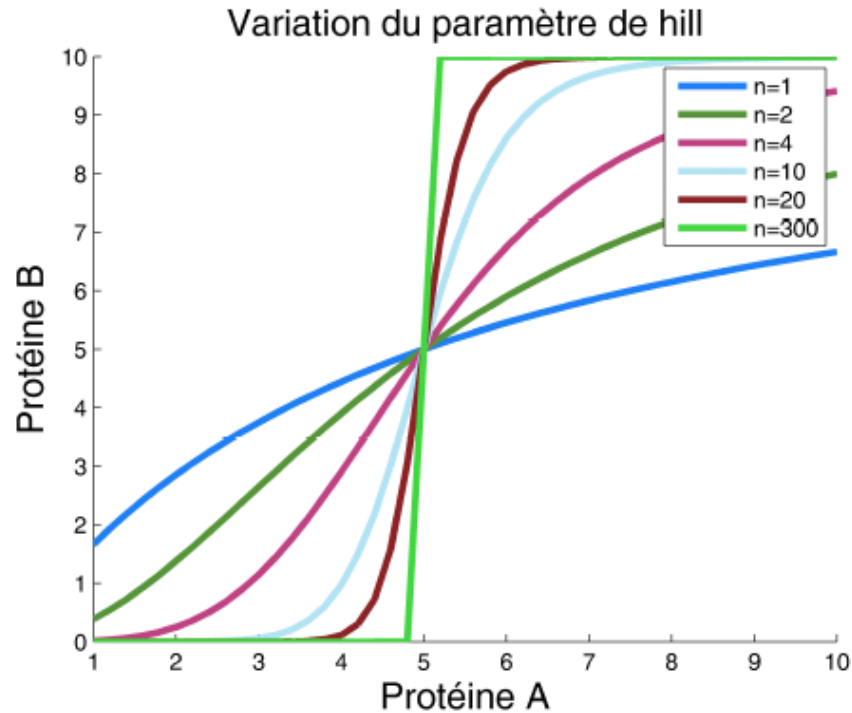

When $n = 1$ → equation of Michaelis and Menten

When n increases, the curve becomes a sigmoid

When $n \rightarrow \infty$, the curve becomes a step function

Hill function – transcriptional regulator

For **repressors** the Hill function decreases with the concentration of active repressor X^* . It is a decreasing S-shaped curve:

$$\frac{d[Y]}{dt} = f(X^*) = \frac{\beta_{max}}{1 + \left(\frac{[X^*]}{K}\right)^n} = \beta_{max} \frac{K^n}{K^n + [X^*]^n}$$

The maximal production rate β_{max} is obtained when $X^* = 0$ (no repressor). Half-maximal repression is reached when the concentration of X^* is equal to K . K is the repression coefficient. Again, the Hill coefficient n determines the steepness of the curve.

Hill function – transcriptional regulator

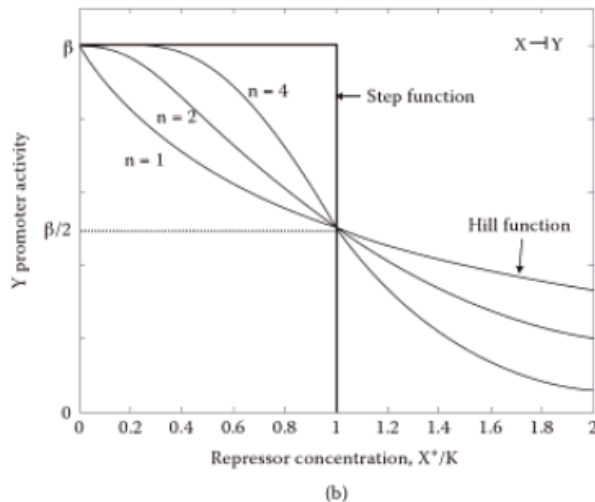
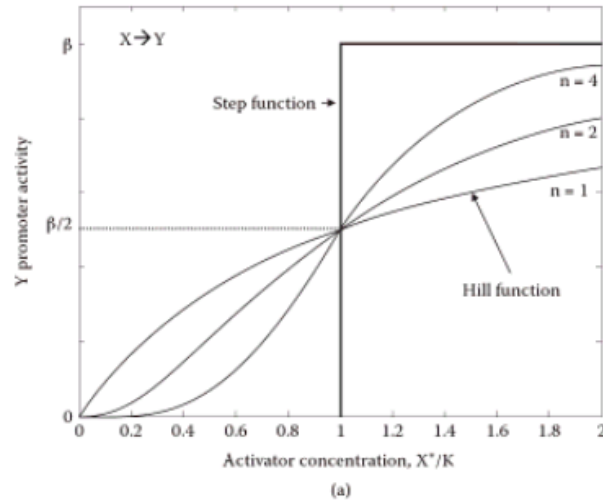

Extracted from :

An introduction to systems Biology (2007) U. Alon
Ed, Chapman & Hall/CRC Mathematical and
Computational Biology Series

FIGu r E 2.4 (a) Input functions for activator X described by Hill functions with Hill coefficient $n = 1, 2,$ and 4 . Promoter activity is plotted as a function of the concentration of X in its active form (X^*). Also shown is a step function, also called a logic input function. The maximal promoter activity is β , and K is the threshold for activation of a target gene (the concentration of X^* needed for 50% maximal activation). (b) Input functions for repressor X described by Hill functions with Hill coefficient $n = 1, 2,$ and 4 . Also shown is the corresponding logic input function (step function). The maximal unexpressed promoter activity is β , and K is the threshold for repression of a target gene (the concentration of X^* needed for 50% maximal repression).

(A) BASIC REACTION TYPES

(a)

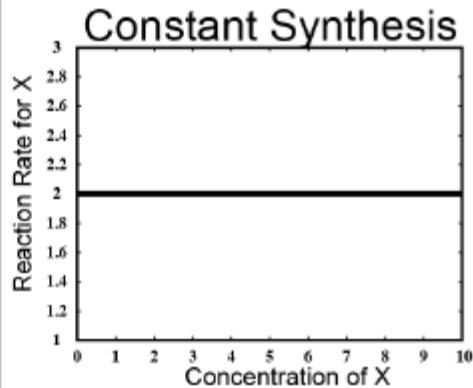

(b)

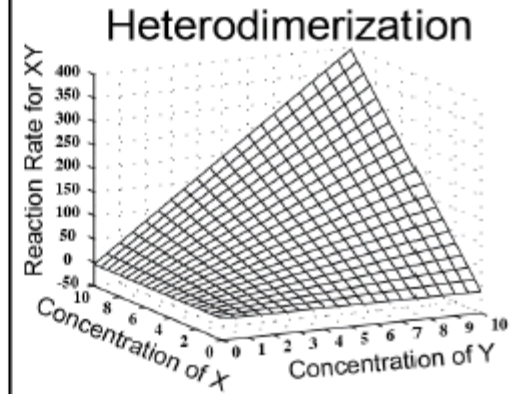
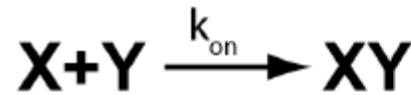

(c)

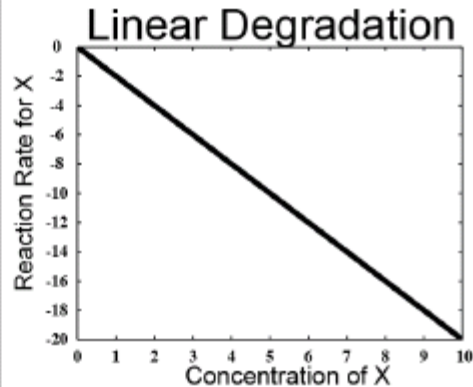
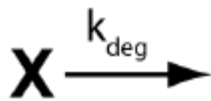

(d)

